

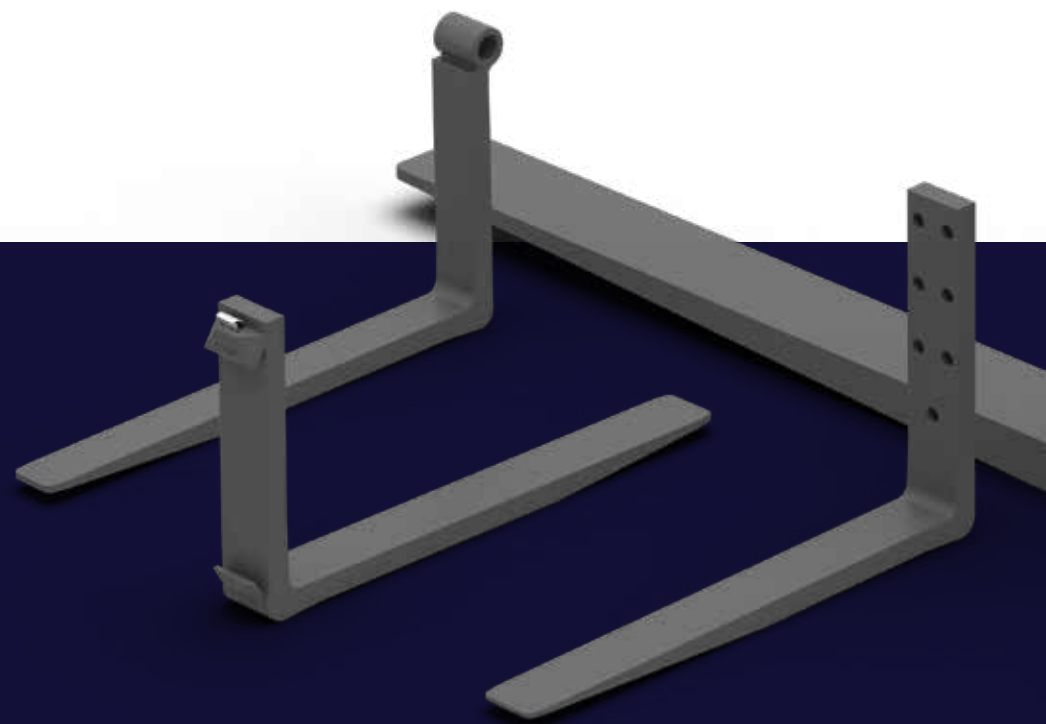

VETTER[®]

Forks, Inc.

Fork News



135 years VETTER

Welcome to the world of VETTER forks

Dear fork friends,

Everyday and future challenges in material handling require practical and implementable solutions. As a leading fork manufacturer, we will be happy to answer your questions and introduce you to our innovative highlights!

With this magazine, we provide you with the most important information about our products and services. We are already looking forward to the next joint project.



Content

It's all about Forks	Page 4
Customized Forks	Page 5
On the spot! - FTP Forks	Page 6
BIGForks	Page 7
ManuTel [®]	Page 8
SmartFork [®]	Page 9
CleverHelpers	Page 10
CROC [®] ForkCoatings	Page 12
VETTER RoadShow	Page 13
About VETTTER	Page 14



Our passion

Everything around us was once transported on a fork. That's why our great passion is to create the best forks in the world - to make logistics more efficient, safer and more sustainable. We are close to the market and to our customers, share our knowledge and take care - personally and individually!

It's all about Forks

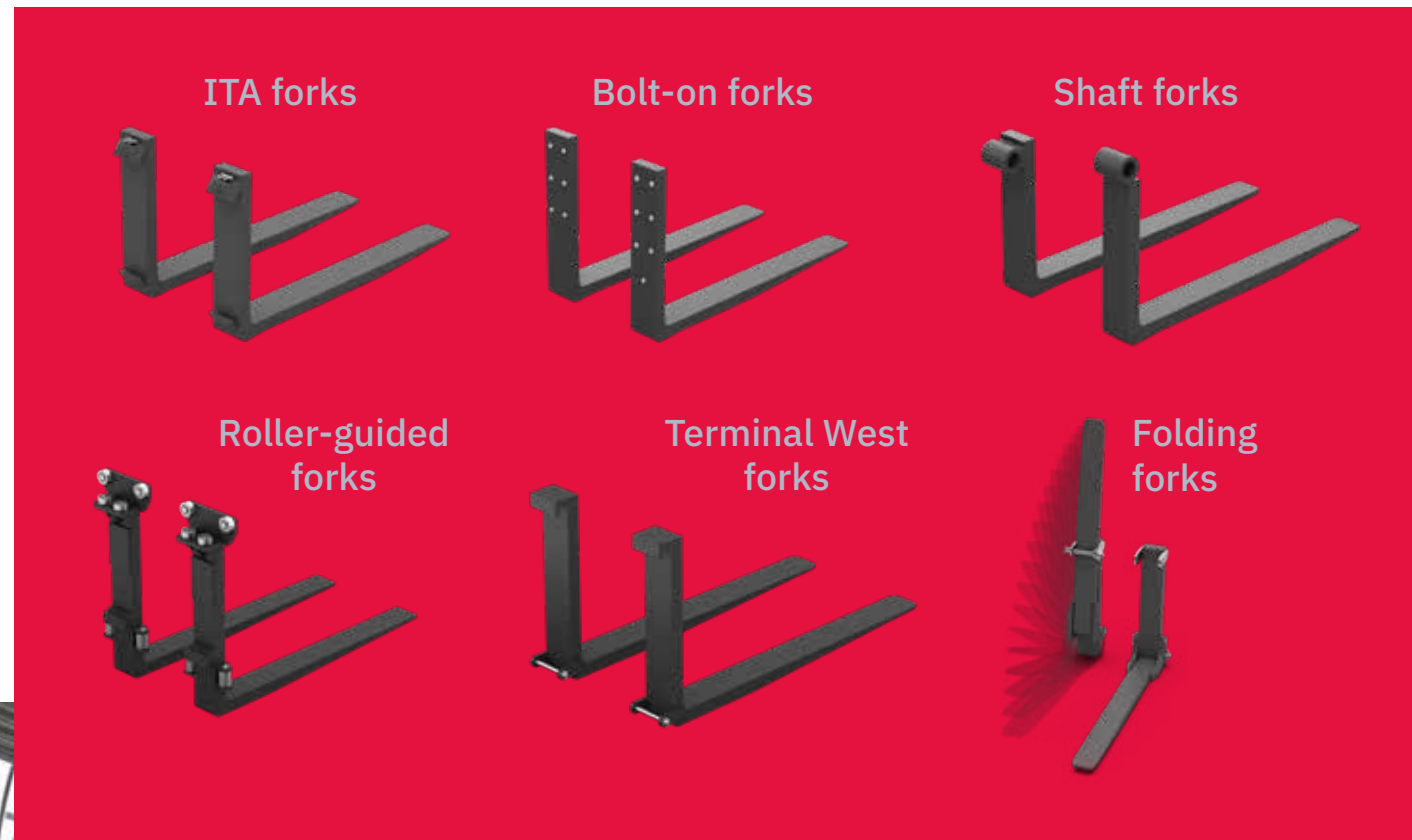

Customized Forks

The VETTER Modification Center customizes forks according to your requirements, specific suspensions, individual blade lengths, special tips, specific mountings, coatings and much more. VETTER Forks, Inc. holds a huge stock of many different fork blank sizes for short lead times.

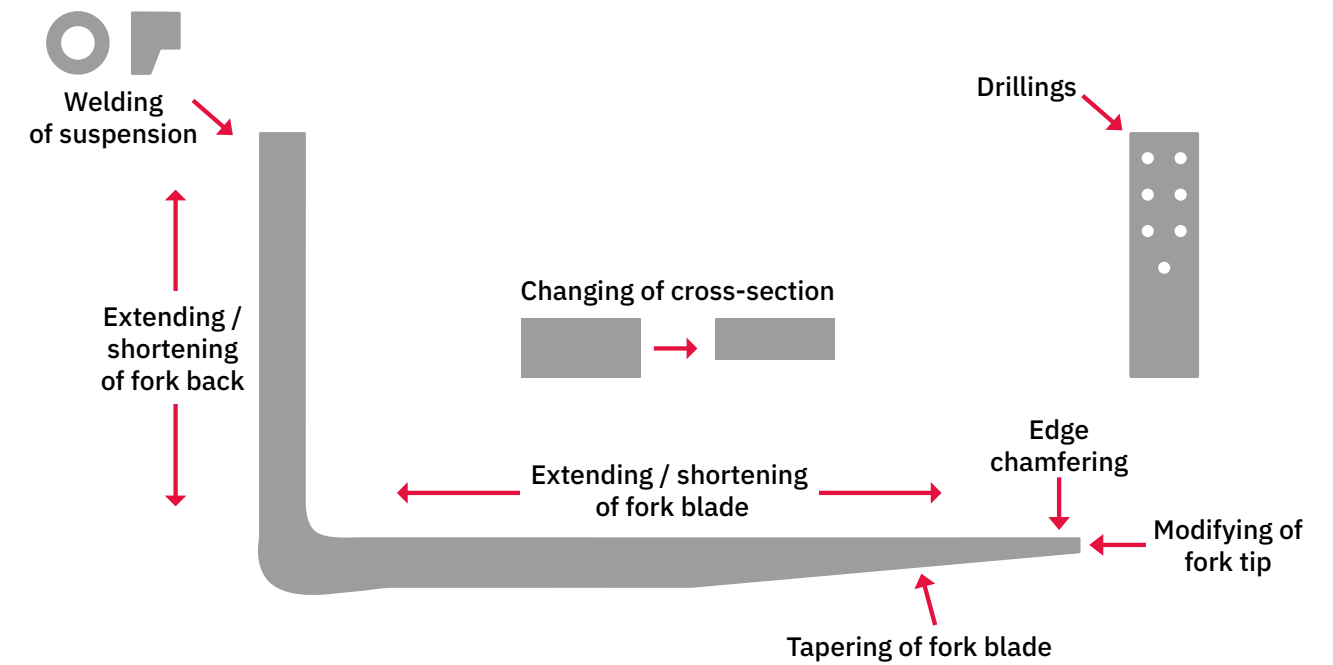

... and all kind of machinings, millings, weldings, cuttings, lacquerings, etc.



FTP Forks

On the spot!

FTP QualityForks

Fully tapered polished
– for lifting stacked material

FTP + Peek-a-boo QualityForks

Best forward visibility for the forklift driver

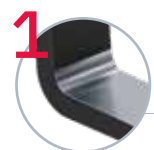
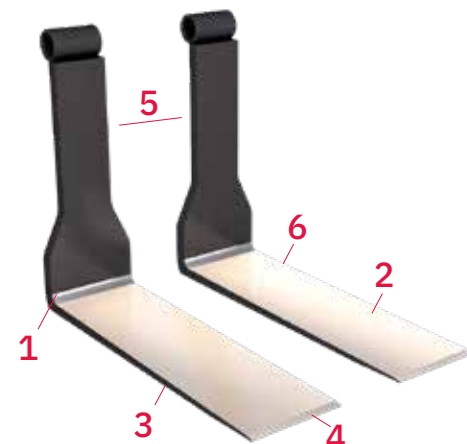
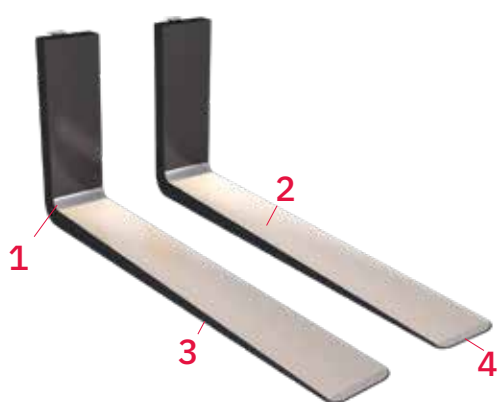

Specific polished heel radius



Beveled fork tip



Polished surface



Waisted shank for better visibility

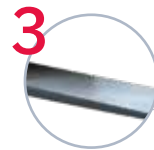

Fully tapered blade

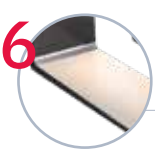

Extra wide blade



BIGForks

Power packages for safe handling of heaviest loads

✓
Safe handling of heaviest loads

✓
High efficiency in rough environments

✓
Safety and endurance in toughest use

Product characteristics

- Sections up to 16" width x 6" thickness *
- Blade lengths up to 16½ ft *
- Back heights up to 80" *
- Capacity per pair up to 286,500 lbs *
- 3x static safety and 1,000,000 load cycles with 25% overload (ISO 2330)
- Example of use: lumber, metal and concrete industry, container ports



* other dimensions on request



ManuTel[®]

Manual Telescopic Fork – Efficient and safe



Truck loading and unloading lateral



Loading of 2 or 3 pallets at once



Time and cost savings

Product characteristics

- Legal conformity according to EC machinery directive
- Easy application without tools or hydraulics
- Robust design, also for all-terrain use
- Example of use: Forwarders, warehouses, DIY superstores, transport of furniture, panels or paper

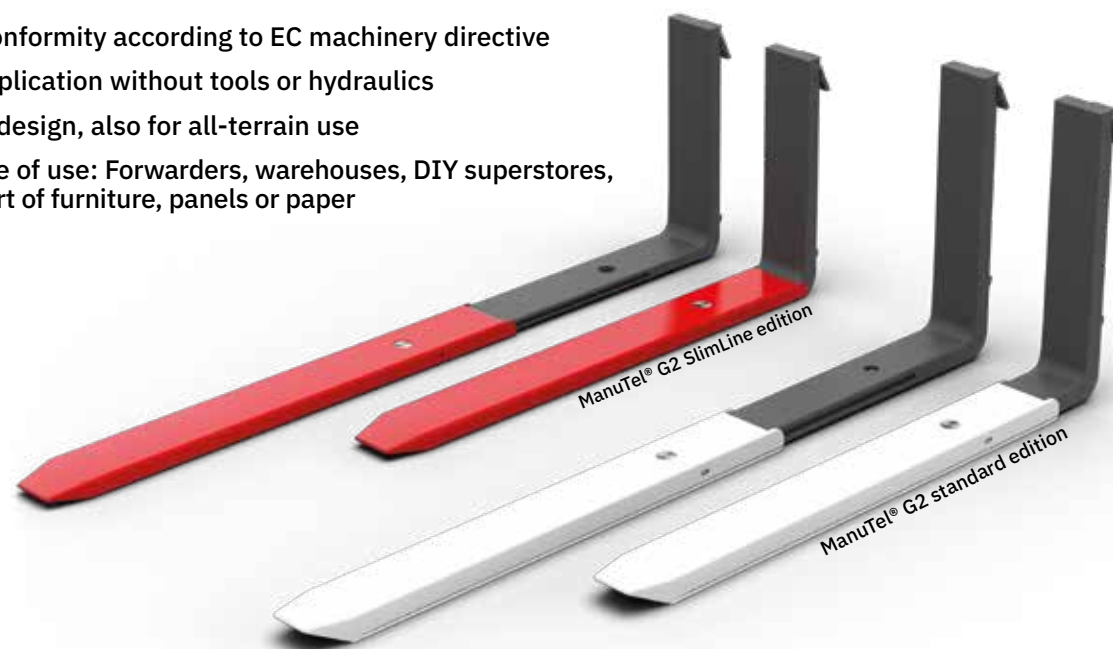

ManuTel[®] G2 SlimLine edition

- Extra-thin blade: only 1.5" thick
- Quick-release pin-locking device for easy length adjustment
- Capacity up to 3,600 lbs

ManuTel[®] G2 standard edition

- Wear-resistant straight manganese steel plate on the lower side of the fork shoe
- Standard capacity up to 12,600 lbs at 24" load centre, other capacities on request

SmartFork[®]

For more safety and less damages



Extended field of vision



Precise targeting



Damage reduction



Improved load handling

Product characteristics

- **SmartFork[®] FrontCam:** Integrated camera in the fork tip
- **SmartFork[®] SideCam:** Semi-integrated camera installation in the lateral fork blade
- **SmartFork[®] Laser:** Integrated laser in the fork tip
- Example of use: logistics and warehousing



CleverHelpers

Retrofit solutions for making the forklift-driver's life easier!

LIZZARD[®]

Camera and laser system

- ✓ Precise and safe targeting of load carriers
- ✓ Extended field of vision
- ✓ Less damage to the transported goods

Product characteristics

- Three options:
LIZZARD Cam: camera incl. monitor
LIZZARD Target: cross laser
LIZZARD Premium: camera, monitor, cross laser
- Simply mounted onto the fork carriage

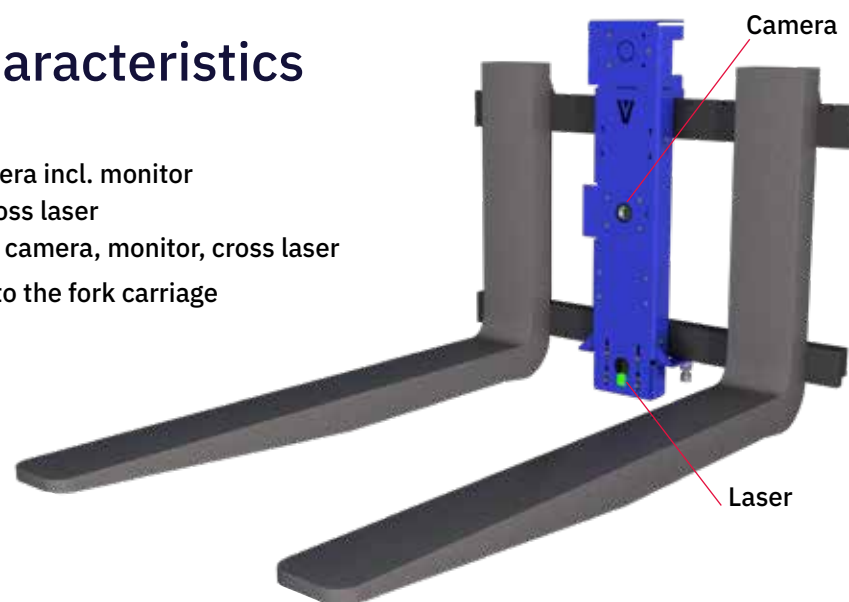

KOALA

Impact protector

- Protection of goods
- Reduces impact intensity
- Noise reduction
- Two options:
KOALA „red“ with two height-adjustable, integrated velcro strips
KOALA „black“ with four integrated round magnets

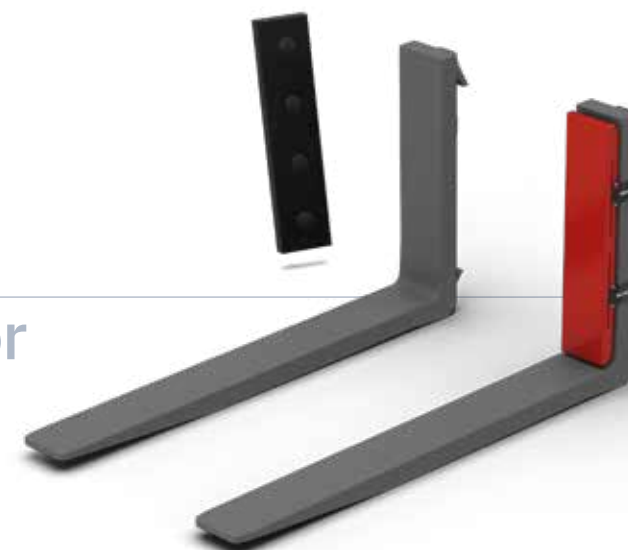

GEKKO

Magnetic anti-slip layer

- Minimized risk of slipping loads
- Reduction of damages, protection of sensitive surfaces
- Noise reduction and less vibrations



CROC[®] ForkCoatings

High slip resistance to protect goods



Stop slipping goods



Less damage to the transported goods



Noise reduction



Increase visibility of fork

Product characteristics

- Standard fork coatings in short lead times
CROC[®] "red unprofiled": Polyurethane, 1/8", 3/16" or 3/8" thick for increased abrasion resistance
CROC[®] GripFix "black": 5/16" thick for increased slip resistance even in wet conditions
- For special requirements additional coatings available
- Equipped with collision protection at the fork tip
- High-tech special adhesive for permanent coating
- High abrasion and cut resistance
- Resistance to oils, acids, chemicals and solvents
- Temperature and weather resistant
- Example of use: transport of sensitive goods, warehousing

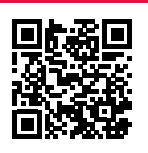
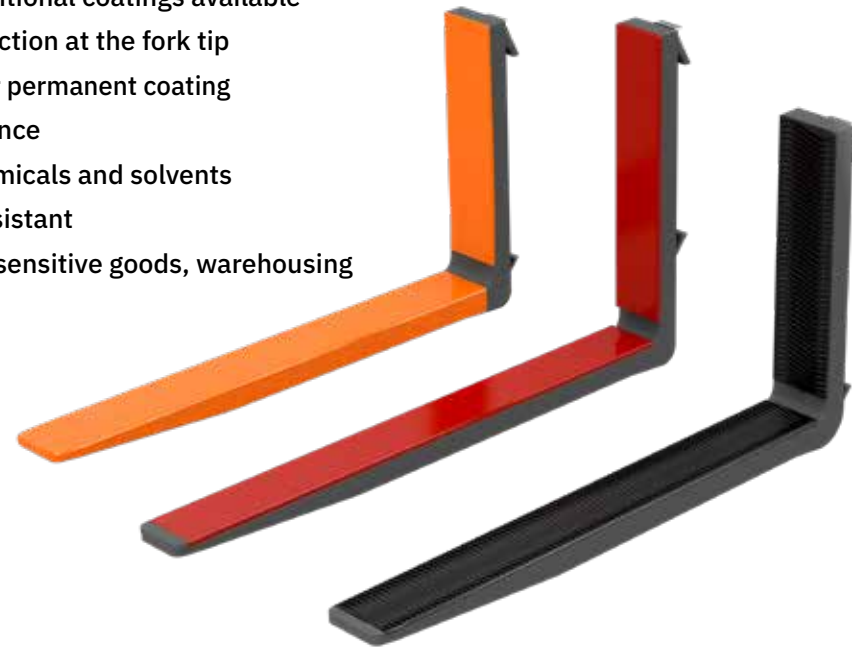

VETTER RoadShow



Experience our clever solutions for intralogistics directly on your site



Live-Tests in real conditions



Get intensive knowledge for resale and improved customer advice



Product training and application advice

VETTER RoadShow soon at your facility? Book now!

Reach out to your VETTER contact person or send us an inquiry to contact@forks.com

About VETTER

VETTER Industrie GmbH is a 5th generation family business being 135 years in the market. For now 60 years VETTER is a preferred supplier to the global industrial truck and construction machinery industry.

Starting out in 1889 with products for the mining industry, VETTER set milestones in fork production over the last decades and is now Europe's leading fork manufacturer. Driven by continuous further developments, VETTER has become a pioneer in smart and intelligent forks that make everyday life for forklift drivers easier and, above all, safer. A pacesetter for modern and sustainable logistics!

VETTER not only supplies forks to make logistics processes more efficient, but also supports customers in fulfilling their mission. Reliability, innovations, expertise and personality are the secrets to mastering the challenges in logistics.

From BasicForks to SpecialFeatures and SmartFork[®] assistance systems - VETTER forks offer the suitable solution for almost any application.

Trusting relationship, open communication, appreciation and recognition of all stakeholders are part of the VETTER philosophy. Thanks to that we are market leader in Europe and a strong supplier in North America.



Burbach / Germany plant I



Burbach / Germany plant II



Burbach / Germany plant III

VETTER Forks, Inc.

VETTER Forks, Inc. in the US was founded 2006 to provide our customers a local warehouse and peace-of-mind in the daily processing. In 2017 a decisive step was made: An own facility was acquired, which gives space to establish certain production steps in the US. Nowadays customized forks can be produced locally with short lead-times to serve your requirements.

A wide variety of QualityForks is stocked for quick delivery. VETTER is a preferred supplier to renowned OEMs, attachment manufacturers and truck dealers. Second to none VETTER is focused on forks, giving unbeatable competence!



Oliver Lotz
General Sales Manager
USA / Canada
OEM Business

+1 717 977 1946
oliver.lotz@forks.com



Scott Shoemaker
Sales Manager
Dealer Business

+1 717 977 0533
scott.shoemaker@forks.com



Dillon Feie
Sales Representative
USA North East, Canada

+1 717 404 8530
dillon.feie@forks.com



Jesse Bitting
Sales Representative

+1 717 331 9912
jesse.bitting@forks.com

Our commitment

✓
Customer first!

✓
We are focused on forks like no one else

✓
We are striving to be the first fork manufacturer becoming climate neutral

✓
We stand for reliability, punctuality and absolute quality - this is our delivery promise

✓
With SmartFork[®] and CleverHelpers we are the pioneers for products that raise efficiency, safety, sustainability and ergonomics in logistics to a new level



Ben Hershberger
Sales Representative
OEM Business

+1 717 404 7280
ben.hershberger@forks.com



Hollie Parsons
Inside Sales Representative
USA Mid West

+1 717 977 9860
hollie.parsons@forks.com



Allison Pettner
Sales Coordinator

+1 717 753 3913
allison.pettner@forks.com



135 years VETTER

2024 is a special year, VETTER is celebrating two anniversaries.

Starting in 1889 with products for the mining industry, VETTER has set milestones in fork production over decades. The first forks were produced in 1964.

VETTER Forks, Inc.
1711 Opportunity Avenue
Chambersburg, PA 17201
USA

+1 717 753 3913
contact@forks.com

www.forks.com

Follow us: 